

THREADED ACCESSORIES

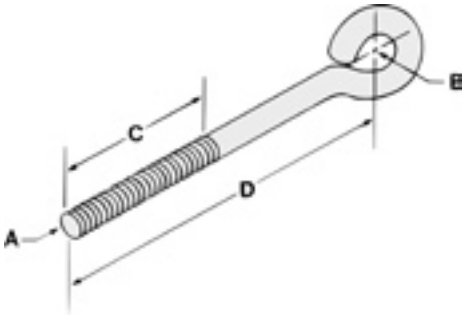

Fig. 50 & 50L EYE ROD

Fig. 50 RIGHT-HAND THREADS
Fig. 50L LEFT-HAND THREADS



FUNCTION: Designed for use in hanger assemblies. The welded design allows the eye to develop the full strength of the rod.

MATERIAL: Low carbon steel

FINISH: Plain

ORDERING: Specify rod size, length and figure number.

Fig. 50 & 50L

Rod Size A	B	Thread Length C	Max. Rec. Load/lbs.	
			650°F	
3/8	1/2	2 1/2	240	
1/2	5/8	2 1/2	440	
5/8	3/4	2 1/2	705	
3/4	7/8	3	1050	
7/8	1	3 1/2	1470	
1	1 1/8	4	1940	

Available in stainless steel. To order, specify 304 or 316 and add suffix SS to figure number. Price on request.

Fig. 55 & 55L WELDED EYE ROD

Fig. 55 RIGHT-HAND THREADS
Fig. 55L LEFT-HAND THREADS

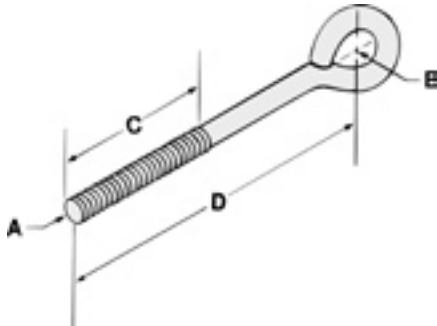

Fig. 55 & 55L

Rod Size A	B	Thread Length C	Max. Rec. Load/lbs.	
			650°F	750°F
3/8	1/2	2 1/2	730	540
1/2	5/8	2 1/2	1350	1010
5/8	3/4	2 1/2	1810	1610
3/4	7/8	3	2710	2420
7/8	1	3 1/2	3770	3360
1	1 1/8	4	4960	4420

Available in stainless steel. To order, specify 304 or 316 and add suffix SS to figure number. Price on request.

Rod Size A	Wt. Each (in lbs.)													
	Length D (inches)													
	8	10	12	14	18	24	30	36	42	48	54	60	66	72
3/8	.32	.38	.44	.50	.63	.80	1.00	1.18	1.39	1.58	1.76	1.95	2.14	2.33
1/2	.60	.70	.82	.94	1.16	1.50	1.83	2.17	2.49	2.83	3.16	3.49	3.83	4.06
5/8	.97	1.14	1.31	1.49	1.84	2.36	2.88	3.40	3.92	4.44	4.96	5.48	6.00	6.52
3/4	1.44	1.68	1.94	2.19	2.68	3.44	4.19	4.94	5.70	6.45	7.20	7.95	8.70	9.45
7/8	2.04	2.32	2.68	3.02	3.73	4.72	5.74	6.76	7.81	8.83	9.85	10.87	11.89	12.91
1	2.67	3.11	3.56	4.00	4.89	6.78	8.18	8.89	10.48	11.87	13.19	14.51	15.91	17.25

Note: Other lengths and thread lengths available upon request.