

# BAND HANGERS



## SWIVEL RING HANGER

## FIG. 151 & 151F

**Function:** Designed for the suspension of non-insulated stationary pipe lines. The knurled insert nut, allows for vertical adjustment after installation. Fig. 151F has a layer of felt which separates the pipe from the hanger to reduce vibration and sound.

**Material:** Carbon steel

**Finish:** Pre-galvanized (**Fig. 151**) or pre-galvanized with felt lining (**Fig. 151F**)

**Approvals:** Underwriters' Laboratories Listed in the U.S. (UL) and Canada (CUL), and Factory Mutual Approved for all sizes. Complies with Federal Specification A-A-1192A (Type 10), and Manufacturers' Standardization Society ANSI/MSS SP-58 (Type 10) which supersedes ANSI/MSS SP-69.

**Ordering:** Specify figure number and pipe size.

*NOTE: If ordering Fig. 151F felt lined hangers for pipe sizes of 3 1/2" (90mm) or under, order the next largest size to allow for the thickness of the felt lining.*

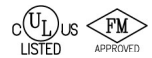
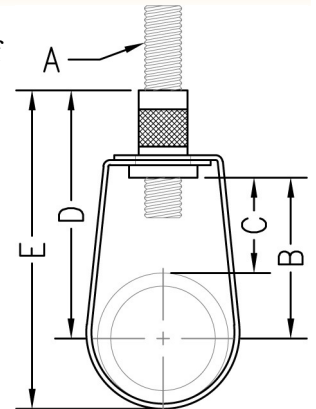

Pipe Size		Rod Size	B		Adj. C		D		E		Max. Rec. Load		Wt. Each	
											lbs.	kN	lbs.	kg
2 1/2	(65)	1/2	2 3/4	(69.85)	1 1/4	(31.75)	3 11/16	(93.66)	5 1/8	(130.18)	600	(2.67)	.33	(.15)
3	(80)	1/2	3 1/8	(79.38)	1 1/8	(28.58)	4	(101.60)	5 7/8	(149.23)	600	(2.67)	.35	(.16)
3 1/2	(90)	1/2	3 5/8	(92.08)	1 1/2	(38.10)	4 5/16	(109.54)	6 5/8	(168.28)	600	(2.67)	.37	(.17)
4	(100)	5/8	3 7/8	(98.43)	1 1/4	(31.75)	4 15/16	(125.41)	7 1/8	(180.98)	1000	(4.45)	.48	(.22)
5	(125)	5/8	3 3/8	(85.73)	1 3/8	(34.93)	5 5/8	(142.88)	8 1/2	(215.90)	1000	(4.45)	.57	(.26)
6	(150)	3/4	5 5/16	(134.94)	2	(50.80)	6 11/16	(169.86)	10 1/8	(257.18)	1250	(5.56)	1.06	(.48)
8	(200)	3/4	6 15/16	(176.21)	2 5/8	(66.68)	8 5/16	(211.14)	12 7/8	(327.03)	1250	(5.56)	1.32	(.60)